



THE PRODUCT

The idea of giving greater expression to ergonomic requirements was the starting point of the development of the SMART-CASE®.

And so the design follows the touch sensation of the human being, thus facilitating natural sequences of hand movements.

Benefit from the outstanding balance between design and technical sophistication.

YOUR ADVANTAGE

Convincing ergonomics; unique design.

Ideal for remote controls, with cables or with battery compartment.

Cable glands for sizes M, L and XL for cables \varnothing 0.134"-0.232". Cable gland already included. (TPE, standard color volcano, NCS S 5502-G)

Optionally in material permeable to infra-red signals from stock. For utmost efficiency the front face is polished.

Recessed operating area to protect the membrane keyboard (M/L/XL).

Fastening pillars and fixing supports for PCBs and components.

APPLICATIONS

Remote controls of all types, wireless or with cable connection.

Especially suitable for use in hospitals and social fields as well as in industry and households.

PROTECTION CLASS IP 65

With sealing (accessories) sizes L and XL versions without battery compartment.

MAX. SIZE OF PCB

SMART-CASE®	L x W/W ₂ in inches	
	base part	top part
XS	1.811 x 1.142/0.709	—
M	2.283 x 1.496/1.181	2.480 x 1.575/1.220
L	3.465 x 1.969/1.654	4.606 x 2.008/1.457
XL	5 x 2.362/1.969	3.071 x 2.362/2.205 +1.969x2.165/1.850

(cutouts of pillars and battery compartment not taken into consideration)



Off-white, RAL 9002
Black, RAL 9005



XS



M



L/XL

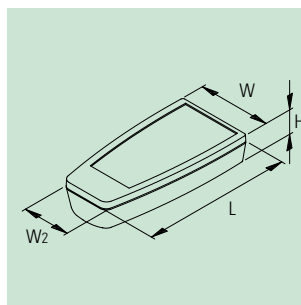

ENCLOSURES

SMART-CASE	Outside dim. in inches			Version / Equipment (dim. in inches)			ABS (UL 94 HB) off-white	Part-No.		
	L	W	H	battery comp.	cable gland ø	max. dim. keypad		ABS (UL 94 HB) black	PMMA (plexiglass®) black*1	
XS	2.283	1.402	0.748	–	–	–	without recessed area	A 90 64 107	A 90 64 109	A 90 64 209
M	3.780	1.850	0.945	I	2 x AAA	–	without recessed area	A 90 66 107	A 90 66 109	A 90 66 209
	3.780	1.850	0.945	II	2 x AAA	–	2.937 x 1.569	A 90 66 117	A 90 66 119	A 90 66 219
	3.780	1.850	0.945	III	–	approx. 0.197 - 0.232	2.937 x 1.569	A 90 66 127	A 90 66 129	–
	3.780	1.850	0.945	IV	–	approx. 0.165 - 0.197	2.937 x 1.569	A 90 66 137	A 90 66 139	–
	3.780	1.850	0.945	V	–	approx. 0.134 - 0.165	2.937 x 1.569	A 90 66 147	A 90 66 149	–
L	5.512	2.469	1.201	I	2 x AA / 1 x 9 V	–	4.093 x 2.006	A 90 67 107	A 90 67 109	A 90 67 209
	5.512	2.469	1.201	II	–	–	4.093 x 2.006	A 90 67 117	A 90 67 119	A 90 67 219
	5.512	2.469	1.201	III	–	approx. 0.197 - 0.232	4.093 x 2.006	A 90 67 127	A 90 67 129	–
	5.512	2.469	1.201	IV	–	approx. 0.165 - 0.197	4.093 x 2.006	A 90 67 137	A 90 67 139	–
	5.512	2.469	1.201	V	–	approx. 0.134 - 0.165	4.093 x 2.006	A 90 67 147	A 90 67 149	–
XL	6.614	2.929	1.394	I	2 x AA / 1 x 9 V	–	4.354 x 2.404	A 90 68 107	A 90 68 109	A 90 68 209
	6.614	2.929	1.394	II	–	–	4.354 x 2.404	A 90 68 117	A 90 68 119	A 90 68 219
	6.614	2.929	1.394	III	–	approx. 0.197 - 0.232	4.354 x 2.404v	A 90 68 127	A 90 68 129	–
	6.614	2.929	1.394	IV	–	approx. 0.165 - 0.197	4.354 x 2.404	A 90 68 137	A 90 68 139	–
	6.614	2.929	1.394	V	–	approx. 0.134 - 0.165	4.354 x 2.404	A 90 68 147	A 90 68 149	–

ACCESSORIES

Article	For enclosure SMART-CASE	Version / Application	Part-No.	
① Set of battery clips	M	tin-plated, for 2 x 1.5 V micro cells (AAA)	A 91 66 001	
	L, XL	tin-plated, for 2 x 1.5 V mignon cells (AA)	A 91 90 002	
② Battery contact	M	tin-plated, for a serial connection when using the set of batt. clips	A 91 66 002	
③ Battery holder	M	clamps down securely 2 x AAA	A 91 66 003	
④ Plug-in contact	L, XL	for one 9 V flat battery	A 91 60 003	
⑤ Sealing	L	for versions II-V, for a higher protection class (IP 65)	A 91 67 002	
	XL	for versions II-V, for a higher protection class (IP 65)	A 91 68 002	
⑥ Set of strain relief	M, L, XL & station	for strain relief of cable connected applications	A 91 66 004	
⑦ Key ring	XS	nickel-plated, ø 0.807"	A 91 64 001	
⑧ Belt / pocket clip	M, L, XL	PA 6, 2 mounting holes ø 0.165" necessary	off-white	A 91 67 017
	M, L, XL	up to ø 1.260", ABS, mounting holes ø 0.165" necessary	black	A 91 67 019
⑨ Holding clamp	M	ABS, also suitable for cable connected applications	A 91 67 027	A 91 67 029
	L	ABS, also suitable for cable connected applications	A 91 66 307	A 91 66 309
⑩ Holder	XL	ABS, also suitable for cable connected applications	A 91 67 307	A 91 67 309
	holder M	double-sided adhesive foil with foam carrier	A 91 68 307	A 91 68 309
⑪ Adhesive foil for holder	holder L	double-sided adhesive foil with foam carrier	A 91 66 005	
	holder XL	double-sided adhesive foil with foam carrier	A 91 67 005	
	holder XL	double-sided adhesive foil with foam carrier	A 91 68 005	
⑫ Station	M	ABS, desk case application (available from December 2009)	A 91 66 037	A 91 66 039
	L	ABS, desk case application (available from November 2009)	A 91 67 037	A 91 67 039
	XL	ABS, desk case application (available from January 2010)	A 91 68 037	A 91 68 039
⑬ Contacts (bore holes necessary)	M, L, XL	contact pin, female for the station, gold-plated, < 15 A, 1-pole	A 91 93 030	
	M, L, XL	spring contact, male for the case, gold-plated, < 15 A, 1-pole	A 91 93 031	



for ring eyelet see page 104

*1 sizes M, L & XL only the bottom parts made of PMMA, top part is made of ABS (UL 94 HB); cases made of PMMA (plexiglass®) not comparable to cases made of ABS in terms of mechanical load-bearing capacity

NEW PRODUCT