



THE PRODUCT

OKW took a completely new approach in the development of SNAPTEC.

Instead of a conventional screw connection, assembly is effected using innovative and rational snap-in technique.

A visual improvement as well. The four openings are only for unlocking the unit for service or adjustment work on the final product, and are almost invisible thanks to the covers.

YOUR ADVANTAGE

Minimum effort with screwless case assembly. Save money, either during production or later with maintenance.

Easy disassembly / servicing.

High robustness and sealed up to IP 65.

Easy wall mounting. Invisible wall mounting in pre-moulded shafts within the base part. As an alternative, there are separate wall mounting brackets for exterior mounting available as accessories.

Recessed operating area to protect the membrane keyboards.

High bottom parts guarantee maximum surface area for fitting screw-in cable glands.

APPLICATIONS

Applications with **electro-technical** components for low voltage, e.g. potentiometers, time controllers, coded control units etc.

Or applications for light voltage with **electro-mechanical** components, e.g. relays, undervoltage no-close release, fuses etc.

PROTECTION CLASS IP 65

With sealing, already prefitted in the top.

MAX. SIZE OF PCB

SNAPTEC	L x W in inches	
	base part	top part
2.362 x 2.362	1.181 x 2.047	1.102 x 1.969
2.362 x 3.937	2.047 x 2.716	1.969 x 2.677
3.937 x 3.937	2.717 x 3.583	2.677 x 3.543

(cutouts for pillars not taken into consideration)

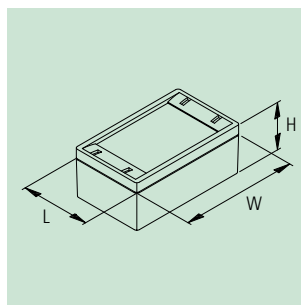

Light gray, RAL 7035

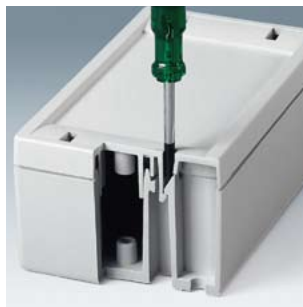

INFO-BOX

Special snap-in techniques: Four snap-in hooks, suitably dimensioned for plastic, guarantee the necessary contact pressure on the seal to achieve the high protection class IP 65. The snap-in hooks can be pushed out of the locking position with the opening tool (included in the kit) or with a commercially available screwdriver (ø 0.118"). The restoring force of the seal lifts up the top part to facilitate opening.

Tests have confirmed that the snap-in technique is reliable, even after opening and closing 100 times. Load-bearing capacity up to 20 kg is guaranteed!



ENCLOSURES*1

SNAPTEC	Outside dim. in inches			Equipment (dim. in inches) max. dim. keypad	Material	Part-No.
	L	W	H			
2.362 x 2.362	2.362	2.362	1.575	1.933 x 1.169	ABS (UL 94 HB)	C 30 06 061
2.362 x 3.937	2.362	3.937	1.575	1.933 x 2.748	ABS (UL 94 HB)	C 30 06 101
3.937 x 3.937	3.937	3.937	3.150	3.547 x 2.748	ABS (UL 94 HB)	C 30 10 101

ACCESSORIES

Article	For enclosure SNAPTEC	Version / Application	Part-No.
① Wall mounting brackets	for all case sizes	for exterior wall mounting, including 4 fixing elements	C 22 99 028

