

# MOUNTING OF PCBs FROM THE FRONT & ABOVE

## THE PRODUCT

The DIN-MODULAR CASE TYPE B is available in three different designs.

For horizontal slide-in mounting of PCBs from the front, there are closed cases with removable front frame and rear panel.

Versions with separate lids allow vertical and horizontal slide-in PCB assembly.

A special version for 19" racks rounds off the comprehensive range.

## YOUR ADVANTAGE

Case made of glass-fibre reinforced Noryl with outstanding mechanical and electrical properties, corresponding to UL-standard 94 V-1.

Available in 3 different designs, depending on the inserts.

All components including the electronic parts can slide into the case from the front side resp. from above, dependent of the case design.

The rear panel has fixing ribs to hold PCBs and slots for the plug connectors.

Holder or bracket for secure mounting within the control panel.

Transparent snap-in cover (accessory) protects displays and operating elements (96 x 48 – 144 x 72).

## APPLICATIONS

Case system for a multitude of applications. Especially suitable for measuring, control technology and remote controls.

## PROTECTION CLASS < IP 40

With snap-in cover up to IP 53 (96 x 48 – 144 x 72).

■ Black

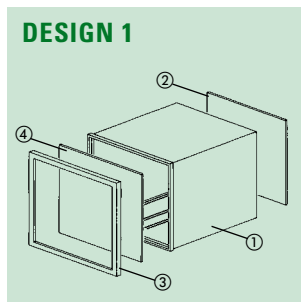

- ① Case
- ② Rear panel of case
- ③ Snap-in front frame
- ④ Front panel/Filter plate (accessory)

Norm dim.:  
96 x 48 / 72 x 72 / 96 x 96 mm

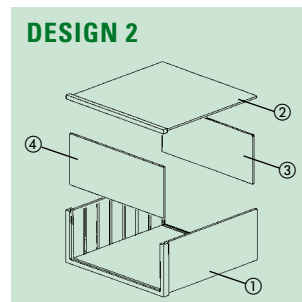

- ① Case U-section
- ② Lateral lid of case
- ③ Rear panel of case
- ④ Front panel/Filter plate (accessory)

Norm dim.:  
144 x 72 / 144 x 144 mm  
(case 142 x 72 additionally with snap-in front frame available)



- ① Case U-section
  - ② Lateral lid of case
  - ③ Rear panel of case
  - ④ Front panel/Filter plate (accessory)
- Same as design 2, but particularly designed for 19"-system slide-in assemblies 12 TE, 3 HE.
- Norm dim.:  
72 x 144 mm

DIN-MODULAR CASES B

## ENCLOSURES

Part-No.	TYPE B	Standard dim. in mm			Design*1	Equipment			Material (UL 94 V-1)
		W	H	L		rear panel	front frame	attachment with	
A 98 42 401	96 x 48	96	48	109	1	no slots	removable	Holding frame (acc.)	Noryl reinforced
A 98 42 402		96	48	109	1	no slots	removable	Holder (accessory)	Noryl reinforced
A 98 42 411		96	48	109	1	1 slot	removable	Holding frame (acc.)	Noryl reinforced
A 98 42 412		96	48	109	1	1 slot	removable	Holder (accessory)	Noryl reinforced
A 98 42 421		96	48	109	1	2 slots	removable	Holding frame (acc.)	Noryl reinforced
A 98 42 422		96	48	109	1	2 slots	removable	Holder (accessory)	Noryl reinforced
A 98 42 501		96	48	150	1	no slots	removable	Holding frame (acc.)	Noryl reinforced
A 98 42 502		96	48	150	1	no slots	removable	Holder (accessory)	Noryl reinforced
A 98 42 511		96	48	150	1	1 slot	removable	Holding frame (acc.)	Noryl reinforced
A 98 42 512		96	48	150	1	1 slot	removable	Holder (accessory)	Noryl reinforced
A 98 42 521		96	48	150	1	2 slots	removable	Holding frame (acc.)	Noryl reinforced
A 98 42 522		96	48	150	1	2 slots	removable	Holder (accessory)	Noryl reinforced
A 98 33 401	72 x 72	72	72	110	1	no slots	removable	Holder (accessory)	Noryl reinforced
A 98 33 411		72	72	110	1	1 slot	removable	Holder (accessory)	Noryl reinforced
A 98 33 421		72	72	110	1	2 slots	removable	Holder (accessory)	Noryl reinforced
A 98 33 501	72	72	150	1	no slots	removable	Holder (accessory)	Noryl reinforced	
A 98 44 101	96 x 96	96	96	51	1	no slots	removable	Holder (accessory)	Noryl reinforced
A 98 44 111		96	96	51	1	1 slot	removable	Holder (accessory)	Noryl reinforced
A 98 44 121		96	96	51	1	2 slots	removable	Holder (accessory)	Noryl reinforced
A 98 44 141		96	96	51	1	4 slots	removable	Holder (accessory)	Noryl reinforced
A 98 44 401		96	96	100	1	no slots	removable	Holder (accessory)	Noryl reinforced
A 98 44 411		96	96	100	1	1 slot	removable	Holder (accessory)	Noryl reinforced
A 98 44 421		96	96	100	1	2 slots	removable	Holder (accessory)	Noryl reinforced
A 98 44 441		96	96	100	1	4 slots	removable	Holder (accessory)	Noryl reinforced
A 98 44 501		96	96	151	1	no slots	removable	Holder (accessory)	Noryl reinforced
A 98 44 511		96	96	151	1	1 slot	removable	Holder (accessory)	Noryl reinforced
A 98 44 541		96	96	151	1	4 slots	removable	Holder (accessory)	Noryl reinforced
A 98 35 301		144 x 72	144	72	94	2	no slots	removable	Holder (accessory)
A 98 35 302	144		72	96	2	no slots	fixed	Holder (accessory)	Noryl reinforced
A 98 35 501	144		72	148	2	no slots	removable	Holder (accessory)	Noryl reinforced
A 98 35 502	144		72	150	2	no slots	fixed	Holder (accessory)	Noryl reinforced
A 98 35 601	144		72	199	2	no slots	removable	Holder (accessory)	Noryl reinforced
A 98 35 602	144		72	200.5	2	no slots	fixed	Holder (accessory)	Noryl reinforced
A 98 35 701	144		72	246	2	no slots	removable	Holder (accessory)	Noryl reinforced
A 98 35 702	144	72	248.5	2	no slots	fixed	Holder (accessory)	Noryl reinforced	
A 98 55 302	144 x 144	144	144	93	2	no slots	fixed	Holder (accessory)	Noryl reinforced
A 98 55 502		144	144	152	2	no slots	fixed	Holder (accessory)	Noryl reinforced
A 98 55 602		144	144	201	2	no slots	fixed	Holder (accessory)	Noryl reinforced
A 98 55 702		144	144	248	2	no slots	fixed	Holder (accessory)	Noryl reinforced
A 98 35 609	19"	72	144	200	3	no slots	fixed	Holder (accessory)	Noryl reinforced
A 98 35 709	(12 TE)	72	144	248	3	no slots	fixed	Holder (accessory)	Noryl reinforced

## INFO-BOX

### Case type B

96 x 48  
72 x 72  
96 x 96  
144 x 72  
144 x 144

### Guide ridges on ... (for slide-in mounting – horizontal from the front or vertical from above)

2 sides, 2 guides each  
2 sides, 2 guides each  
2 sides, 4 guides each  
2 sides, 1 guide horizontally, various guides vertically with interruption for horizontal slide-in mounting  
2 sides, 1 guide horizontally, various guides vertically with interruption for horizontal slide-in mounting

\*1 for description of the designs see page 97;

design 3 cases are supplied fully assembled (1 case U-section, 1 lid with screws, 1 rear panel, 2 PCB supports with in 1 TE steps,

1 plug holder for connectors acc. to DIN 41 612 and 2 tapped and threaded strips for fixing the components), control board cutout 68 x 138 mm

# DIN-MODULAR CASES TYPE B

acc. to DIN IEC 61 554

## ACCESSORIES

DIN-MODULAR CASE TYPE B	For enclosure	Front panel		Filter plate	
		matt anod. al, 1 pc	red, 1 mm, 2 pcs	red, 2 mm, 1 pc	red, 3 mm, 1 pc
96 x 48		A 91 84 221	A 91 84 213	A 91 84 222	—
	dim. in mm	91.3 x 42.4 x 2	91.3 x 42.4 x 1	91.5 x 42.5 x 2	
72 x 72		A 91 83 321	A 91 83 313	A 91 83 322	—
	dim. in mm	67.8 x 67.8 x 2	67.8 x 67.8 x 1	67.8 x 67.8 x 2	
96 x 96		A 91 84 421	A 91 84 413	A 91 84 422	—
	dim. in mm	91.3 x 91.3 x 2	91.3 x 91.3 x 1	91.5 x 91.5 x 2	
144 x 72		A 91 83 531	—	—	A 91 83 532
	dim. in mm	137.5 x 65.8 x 3			137.5 x 65.8 x 3
144 x 144		A 91 85 531	—	—	A 91 85 532
	dim. in mm	137.5 x 137.5 x 3			137.5 x 137.5 x 3

Article	For enclosure DIN-MODULAR CASE TYPE B	Version / Application	Part-No.
① Holding frame	96 x 48 (please pay attention to the relevant version)	plastic, 1 pc incl. screws	A 92 84 202
② Holder	96 x 48 109 long (please pay att. to the relevant vers.)	steel, 2 pcs incl. thumb nuts	A 92 83 361
	96 x 48 150 long (please pay att. to the relevant vers.)	steel, 2 pcs incl. thumb nuts	A 92 84 251
	72 x 72 110 long	steel, 2 pcs incl. thumb nuts	A 92 83 341
	72 x 72 150 long	steel, 2 pcs incl. thumb nuts	A 92 83 351
	96 x 96 51 long	steel, 2 pcs incl. thumb nuts	A 92 84 511
	96 x 96 100 long	steel, 2 pcs incl. thumb nuts	A 92 84 541
	96 x 96 151 long	steel, 2 pcs incl. thumb nuts	A 92 84 551
	144 x 72 94 long	steel, with rib, 2 pcs incl. nuts	A 92 83 531
	144 x 72 148 long	steel, with rib, 2 pcs incl. thumb nuts	A 92 83 551
	144 x 72 199 long	steel, with rib, 2 pcs incl. thumb nuts	A 92 83 561
	144 x 72 246 long	steel, with rib, 2 pcs incl. thumb nuts	A 92 83 571
	③ Holder	144 x 72 / 144 x 144 / 19" with fixed front frame	set with 2 pcs
④ Snap-in cover	96 x 48	PC transparent (IP 53), 1 pc	A 92 84 204
	72 x 72	PC transparent (IP 53), 1 pc	A 92 83 304
	96 x 96	PC transparent (IP 53), 1 pc	A 92 84 404
	144 x 72 with removal front frame	PC transparent (IP 53), 1 pc	A 92 83 504

