

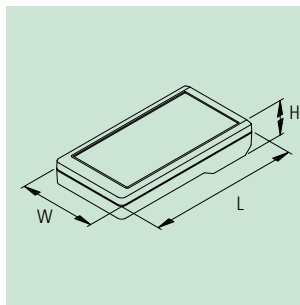

Off-white, RAL 9002
 Black, RAL 9005



THE PRODUCT

A series of cases tailored exactly to the field of mobile data collection has been developed under the name DATEC-MOBIL-BOX®.

The cases combine robust functionality with a design that received an award from the iF (International Forum Design) in Hanover.

YOUR ADVANTAGE

Installation of standardized LCDs possible (contact addresses www.okw.com).

Display windows protect the fitted display modules and guarantee a high protection class IP 65 in the display area. Easy assembly with included adhesive foil.

With and without battery compartment, externally accessible.

Robust construction and attractive design.

Plain surfaces for interfaces.

Recessed operating area in order to protect the membrane keyboards.

Fastening pillars for PCBs and components. Eurocard format in size L.

Tilt foot bar for ergonomically favourable inclination, and wall suspension element for reliable storage available as accessories.

APPLICATIONS

Particularly suitable for harsh environments.

Mobile data recording and transfer. Measuring and control technology. Stock and sales logging. Digital controlling technology.

PROTECTION CLASS IP 65

With sealing kit (accessory) and in versions II-IV only in conjunction with the adhesive foil for the display window.

MAX. SIZE OF PCB

DATEC-MOBIL-BOX®	L x W in inches	
	bottom part	top part
S	5.591/4.094 x 2.835	5.551 x 2.835
M	6.496/4.528 x 3.543	7.244 x 3.543
L	9.331/7.480 x 4.252	9.488 x 4.331

(without/with battery compartment, cutouts for pillars not taken into consideration)

ENCLOSURES

DATEC-MOBIL-BOX®	Outside dim. in inches			Version / Equipment (dim. in inches)			Material	Part-No.		
	L	W	H	battery comp.	for LCD type*1	max. dim. keypad		off-white	black	
S	5.984	3.268	1.319	I	2 x AA / 1 x 9 V	(no window)	5.079 x 2.665	ABS (UL 94 HB)	A 90 73 107	A 90 73 109
	5.984	3.268	1.319	II	2 x AA / 1 x 9 V	2"-LC-Glass Mod.	5.079 x 2.665	ABS (UL 94 HB)	A 90 73 207	A 90 73 209
	5.984	3.268	1.319	III	2 x AA / 1 x 9 V	2 x 20 miniature	5.079 x 2.665	ABS (UL 94 HB)	A 90 73 307	A 90 73 309
	5.984	3.268	1.319	IV	2 x AA / 1 x 9 V	4 x 20 miniature	5.079 x 2.665	ABS (UL 94 HB)	A 90 73 407	A 90 73 409
	5.984	3.268	1.319	I	–	(no window)	5.079 x 2.665	ABS (UL 94 HB)	A 90 73 117	A 90 73 119
	5.984	3.268	1.319	II	–	2"-LC-Glass Mod.	5.079 x 2.665	ABS (UL 94 HB)	A 90 73 217	A 90 73 219
	5.984	3.268	1.319	III	–	2 x 20 miniature	5.079 x 2.665	ABS (UL 94 HB)	A 90 73 317	A 90 73 319
	5.984	3.268	1.319	IV	–	4 x 20 miniature	5.079 x 2.665	ABS (UL 94 HB)	A 90 73 417	A 90 73 419
M	7.677	3.976	1.732	I	• (see acc. ①)	(no window)	6.602 x 3.177	ABS (UL 94 HB)	A 90 74 107	A 90 74 109
	7.677	3.976	2.323	I	• (see acc. ①)	(no window)	6.602 x 3.177	ABS (UL 94 HB)	A 90 74 127	A 90 74 129
	7.677	3.976	1.732	II	• (see acc. ①)	2 x 16 standard	6.602 x 3.177	ABS (UL 94 HB)	A 90 74 207	A 90 74 209
	7.677	3.976	2.323	II	• (see acc. ①)	2 x 16 standard	6.602 x 3.177	ABS (UL 94 HB)	A 90 74 227	A 90 74 229
	7.677	3.976	1.732	III	• (see acc. ①)	2 x 16 compact	6.602 x 3.177	ABS (UL 94 HB)	A 90 74 307	A 90 74 309
	7.677	3.976	1.732	IV	• (see acc. ①)	4 x 16 standard	6.602 x 3.177	ABS (UL 94 HB)	A 90 74 407	A 90 74 409
L	9.921	4.764	1.969	I	4 x AA / 1 x 9 V	(no window)	8.610 x 3.965	ABS (UL 94 HB)	A 90 75 107	A 90 75 109
	9.921	4.764	1.969	II	4 x AA / 1 x 9 V	4 x 20	8.610 x 3.965	ABS (UL 94 HB)	A 90 75 207	A 90 75 209
	9.921	4.764	1.969	I	–	(no window)	8.610 x 3.965	ABS (UL 94 HB)	A 90 75 117	A 90 75 119
	9.921	4.764	1.969	II	–	4 x 20	8.610 x 3.965	ABS (UL 94 HB)	A 90 75 217	A 90 75 219

ACCESSORIES

Article	Version / Application	Part-No.						
		S	M	L				
① Set of battery compartment	ABS, off-white, for 4 x 1.5 V mignon cells (AA), battery clips nickel-plated*2	–	A 93 45 217	–				
② Battery compartment	ABS, off-white, for 1 x 9 V flat battery	–	A 91 74 003	–				
	ABS, off-white, for 2 x 9 V flat batteries	–	A 91 74 002	–				
③ Set of battery clips	nickel-plated, for 2 x 1.5 V mignon cells (AA)*2	A 91 90 011	–	–				
	nickel-plated, for 4 x 1.5 V mignon cells (AA)*2	–	–	A 91 90 012				
	tin-plated, for 1 x 9 V flat battery	–	A 91 74 006	–				
	tin-plated, for 2 x 9 V flat batteries	–	A 91 61 002	–				
④ 9 V contact kit	for 1 x 9 V flat battery, provides polarity and torsion protection	A 91 73 010	–	–				
⑤ Plug-in contact	for 1 x 9 V flat battery	A 91 60 003	A 91 60 003	A 91 60 003				
⑥ Battery spacer	PE foam with one-sided adhesive coating, to secure the mignon cells (AA)	A 92 50 250	–	–				
⑦ Sealing kit	for sealing up to IP 65	A 91 73 001	A 91 74 001	A 91 75 001				
⑧ Tilt foot bar	off-white, 2 mounting holes ø 0.165" necessary	A 92 50 907	A 92 50 907	–				
	black, 2 mounting holes ø 0.165" necessary	A 92 50 909	A 92 50 909	–				
⑨ Non-slip pads	clear, self-adhesive, for the enclosures with tilt foot bar application	A 92 07 150	A 92 07 150	–				
⑩ Wall suspension element (exception size M, 2.323" height)	ABS, off-white, for secure storage of the case	A 92 26 237	A 92 26 227	A 92 26 127				
	ABS, black, for secure storage of the case	A 92 26 239	A 92 26 229	A 92 26 129				
⑪ Protector	Elastomer, volcano, absorbs impacts and for surface protection	–	–	A 91 75 108				
		for LCD type *1	2"-LC-Glass Mod.	2 x 16 compact	2 x 16 standard	4 x 16 standard	2 x 20 miniature	4 x 20...
⑫ Display window (Set with adhesive foil for protection class IP 65)	S acrylic glass, border off-white	A 91 73 007	–	–	–	–	A 91 73 307	A 91 73 407
	S acrylic glass, border black	A 91 73 009	–	–	–	–	A 91 73 309	A 91 73 409
	M acrylic glass, border off-white	–	A 91 74 307	A 91 74 007	A 91 74 407	–	–	–
	M acrylic glass, border black	–	A 91 74 309	A 91 74 009	A 91 74 409	–	–	–
	L acrylic glass, border off-white	–	–	–	–	–	–	A 91 75 007
	L acrylic glass, border black	–	–	–	–	–	–	A 91 75 009

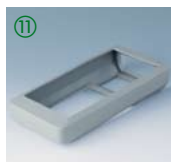

*1 installation on existing fixing pillars in the top part; for a list of matching standard LCDs and contact addresses, please see Internet www.okw.com

*2 complies with DIN EN 60601 (short circuit caused by incorrect insertion of batteries impossible)

NEW PRODUCT