

Off-white, RAL 9002

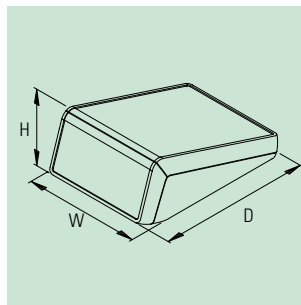

THE PRODUCT

The new UNITEC range of cases is characterised by two operating panels with different inclinations at right angles to each other.

Depending on the application, these can be used for operating and/or reading-off purposes, thus allowing simultaneous applications, for example a doctor face to face with a patient.

YOUR ADVANTAGE

Modern appearance, ideally suited for desk-top or wall mounting.

Generously dimensioned dialog fields (72°/18° inclination). Ideal for large displays, touch screen surfaces, membrane keyboards (1.4 mm depth), graphic overlays (0.6 mm depth), interfaces etc.

Pushbuttons, switches and display elements can be ergonomically operated and read off.

High degree of individualisation possible.

Individual electronics cases can be created through the use of an all-round digital graphic overlay specially tailored to illustrate your corporate identity (top and front parts recessed by 0.6 mm). *1

Flexible component mounting. Printed circuit boards can be positioned in the bottom, top and front parts. Since the operating panels are positioned at right angles to each other, it is also possible to install electronics and interfaces as complete ready-made packages.

With/without battery operation 3 x AA / 5 x AA. Battery comp. lid snap-in and/or screw-on.

APPLICATIONS

Data acquisition systems. Building installations. Data systems engineering. Communication. Analysis, diagnostics and therapy applications. Measuring and control technology.

PROTECTION CLASS IP 40

MAX. SIZE OF PCB

UNITEC	W x D (mm)	W x D (mm)	W x H (mm)
	bottom part	top part	front part
S	112 x 134/30	112 x 148	112 x 48
M	132 x 166/62	132 x 180	132 x 60

(cutouts for pillars not taken into consideration, bottom part without/with battery compartment)

SINGLE OR DUAL OPERATING AREAS



Front part recessed 0.6 mm.
Top part recessed 0.6 mm.
All-round graphic overlays may also be used!



Front part recessed 1.4 mm.
Top part recessed 1.4 mm.
Two membrane keyboards may be used.



Front part recessed 1.4 mm.
Top part recessed 0.6 mm.



Front part recessed 0.6 mm.
Top part recessed 1.4 mm.

ENCLOSURES

UNITEC	Outside dim. in mm			Equipment (dim. in mm)				Material	without battery comp.	Part-No.	
	W	H	D	recess front / top part	recess front / top part	max. dim. keypad front part	max. dim. keypad top part			for 3 x AA*2	for 5 x AA*2
S (available from February 2010)	125	177	69/22	0.6	0.6	—	—	ABS (UL 94 HB)	B 40 54 107	B 40 54 207	B 40 54 307
	125	177	69/22	1.4	1.4	108.4 x 49.5	108.4 x 149	ABS (UL 94 HB)	B 40 54 117	B 40 54 217	B 40 54 317
	125	177	69/22	1.4	0.6	108.4 x 49.5	—	ABS (UL 94 HB)	B 40 54 127	B 40 54 227	B 40 54 327
	125	177	69/22	0.6	1.4	—	108.4 x 149	ABS (UL 94 HB)	B 40 54 137	B 40 54 237	B 40 54 337
M	148	210	80/25	0.6	0.6	—	—	ABS (UL 94 HB)	B 40 56 107	B 40 56 207	B 40 56 307
	148	210	80/25	1.4	1.4	127.6 x 58.6	127.6 x 178.6	ABS (UL 94 HB)	B 40 56 117	B 40 56 217	B 40 56 317
	148	210	80/25	1.4	0.6	127.6 x 58.6	—	ABS (UL 94 HB)	B 40 56 127	B 40 56 227	B 40 56 327
	148	210	80/25	0.6	1.4	—	127.6 x 178.6	ABS (UL 94 HB)	B 40 56 137	B 40 56 237	B 40 56 337

ACCESSORIES

Article	For enclosure UNITEC	Version / Application	Part-No.
① Wall suspension element	S	ABS, off-white, 1 set	B 41 54 307
	M	ABS, off-white, 1 set	B 41 56 307
② Non-slip pads	S, M	ø 12 mm, transparent, self-adhesive, for desk-top applications, 1 pair	A 92 12 330
③ Self-tapping screw	S, M	ø 3 x 6 mm (PZ1), for mounting PCBs, 1 pc	A 03 06 031



*1 on request we can print and mount digital graphic overlays for you in our own Service Centre

*2 battery compartment and lid made of ABS, off-white; battery clips nickel-plated

NEW PRODUCT