



THE PRODUCT

The pocket-sized DATEC-POCKET-BOX® range offers a remarkable amount of technology in a minimum of space, as well as sturdy construction.

The sealings fitted in the upper and lower parts ensure greater protection against dust and water entry.

This means that the case can easily be used in rough conditions.

YOUR ADVANTAGE

Plain surfaces for individual machining and interfaces.

Robust and sealed up to protection class IP 54.

No mounting necessary for the sealing ring. It's already integrated in the top part.

Optionally in infra-red permeable material from stock. For utmost efficiency the case is equipped with a recessed, polished front face (M/L).

Recessed operating area for the protection of the membrane keyboards.

Fastening pillars for PCBs and components.

Externally accessible battery compartment (M/L).

APPLICATIONS

Especially suitable for measuring and control technology, remote controls, pulse generator for ultra-sound and infra-red, wireless communication, mobile data recording.

PROTECTION CLASS IP 54

Only for versions with sealing.

MAX. SIZE OF PCB

DATEC-POCKET-BOX	L x W in inches	
	base part	top part
S	1.732 x 1.535	—
M	2.362 x 2.008	2.835 x 2.008
L	2.677 x 2.283	3.189 x 2.283

(cutouts of pillars not taken into consideration)



Off-white, RAL 9002
 Black, RAL 9005

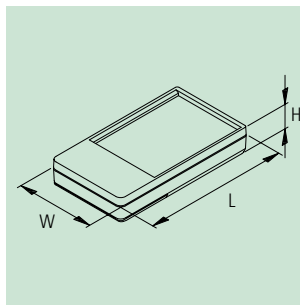

ENCLOSURES

DATEC-POCKET-BOX®	Outside dim. in inches			Equipment (dim. in inches)				Material base part/top part	Part-No.	
	L	W	H	battery comp.	lid of batt.comp.	max. dim. keypad	sealing		off-white	black
S	3.346	1.811	0.630	2 x N	–	2.280 x 1.571	–	ABS (UL 94 HB)	A 90 70 107	A 90 70 109
	3.346	1.811	0.630	2 x N	–	2.280 x 1.571	• (IP 54)	ABS (UL 94 HB)	A 90 70 117	A 90 70 119
	3.346	1.811	0.630	2 x N	–	2.280 x 1.571	–	PMMA (plexiglass®)*1	–	A 90 70 209
	3.346	1.811	0.630	2 x N	–	2.280 x 1.571	• (IP 54)	PMMA (plexiglass®)*1	–	A 90 70 219
M	4.134	2.283	0.728	2 x AAA	screwed down	2.833 x 1.967	–	ABS (UL 94 HB)	A 90 71 107	A 90 71 109
	4.134	2.283	0.728	2 x AAA	screwed down	2.833 x 1.967	• (IP 54)	ABS (UL 94 HB)	A 90 71 117	A 90 71 119
	4.134	2.283	0.728	2 x AAA	screwed down	2.833 x 1.967	–	PMMA (plexiglass®)*1/ABS	–	A 90 71 209
	4.134	2.283	0.728	2 x AAA	screwed down	2.833 x 1.967	• (IP 54)	PMMA (plexiglass®)*1/ABS	–	A 90 71 219
L	4.724	2.559	0.866	2 x AA / 1 x 9 V	screwed down	3.138 x 2.157	–	ABS (UL 94 HB)	A 90 72 107	A 90 72 109
	4.724	2.559	0.866	2 x AA / 1 x 9 V	screwed down	3.138 x 2.157	• (IP 54)	ABS (UL 94 HB)	A 90 72 117	A 90 72 119
	4.724	2.559	0.866	2 x AA / 1 x 9 V	clip-lock	3.138 x 2.157	–	ABS (UL 94 HB)	A 90 72 127	A 90 72 129
	4.724	2.559	0.866	2 x AA / 1 x 9 V	screwed down	3.138 x 2.157	–	PMMA (plexiglass®)*1/ABS	–	A 90 72 209
	4.724	2.559	0.866	2 x AA / 1 x 9 V	screwed down	3.138 x 2.157	• (IP 54)	PMMA (plexiglass®)*1/ABS	–	A 90 72 219
	4.724	2.559	0.866	2 x AA / 1 x 9 V	clip-lock	3.138 x 2.157	–	PMMA (plexiglass®)*1/ABS	–	A 90 72 229

ACCESSORIES

Article	For enclosure DATEC-POCKET-BOX®	Version / Application	Part-No.
① Set of battery clips	S, M, L	tin-plated, for 2 x N / 2 x AAA / 2 x AA	A 91 90 002
② Plug-in contact	L	for one 9 V flat battery	A 91 60 003
③ Battery spacer	L	PE foam with adhesive coating, to secure the mignon cells (AA)	A 92 50 250
④ Ring eyelet	S, M, L	plastic, volcano, inside ring diameter 0.098", max. wall thickness 0.118", location hole ø 0.157" required	A 91 00 001
⑤ Hand strap "Woven"	S, M, L	grey, with quick-action lock, approx. 7.874" long	B 91 00 044
⑥ Carrying strap "Reflex"	S, M, L	silver/black, with quick-action lock, approx. 33.858" long	B 91 00 022
			off-white black
⑦ Belt / pocket clip	S, M, L	ABS, 2 mounting holes ø 0.165" necessary	A 91 72 107 A 91 72 109



*1 cases made of PMMA (plexiglass®) not comparable to cases made of ABS in terms of mechanical load-bearing capacity

NEW PRODUCT