











ASSEMBLY INSTRUCTION – INSTRUCTION DE MONTAGE  
MONTAGEANLEITUNG





	<b>GEHÄUSE / ENCLOSURE / BOÎTIER</b>	<b>Seite / page</b>	<b>Best.-Nr./Part-No./Réf.</b>	
			<b>M</b>	<b>L</b>
	DATEC-CONTROL M/L	4	A 90 78 107 A 90 78 207 A 90 78 109 A 90 78 209	A 90 79 107 A 90 79 207 A 90 79 109 A 90 79 209
	<b>ZUBEHÖR / ACCESSORIES / ACCESSOIRES</b>	<b>Seite / page</b>	<b>Best.-Nr./Part-No./Réf.</b>	
	Displayscheibe Display window Plaque	5	A 91 78 001	A 91 79 001
	Sockel, Tischversion Station, desktop version Socle, version de table	6	A 91 78 137 A 91 78 139	
	Sockel, Wandversion Station, wall mounting Socle, version murale	7	A 91 78 167 A 91 78 169	
	Halter für Batteriefach Battery compartment holder Support du compartiment piles	8	A 91 78 118	
	Batteriefach Battery compartment Compartiment piles	9	A 91 78 128 A 91 78 158	
	PCMCIA-Karte PCMCIA-Card PCMCIA-Carte	10	A 91 78 188 A 91 78 198	
	Kontakte Contacts	11	A 91 78 007 A 91 78 008	
	Dichtungs-Set Sealing kit Jeu de joints	12	A 91 78 006 A 91 79 006	
	Abmessungen der Leiterplatten Dimensions for PCBs Encombrement pour circuit imprimé	13-15		

Gehäuse  
Enclosure  
Boîtier

M	L
A 90 78 107	A 90 79 107
A 90 78 207	A 90 79 207
A 90 78 109	A 90 79 109
A 90 78 209	A 90 79 209

Bitte Montage-  
reihenfolge beachten!  
Please respect the  
succession of mounting!  
Veuillez respecter  
la suite de montage!

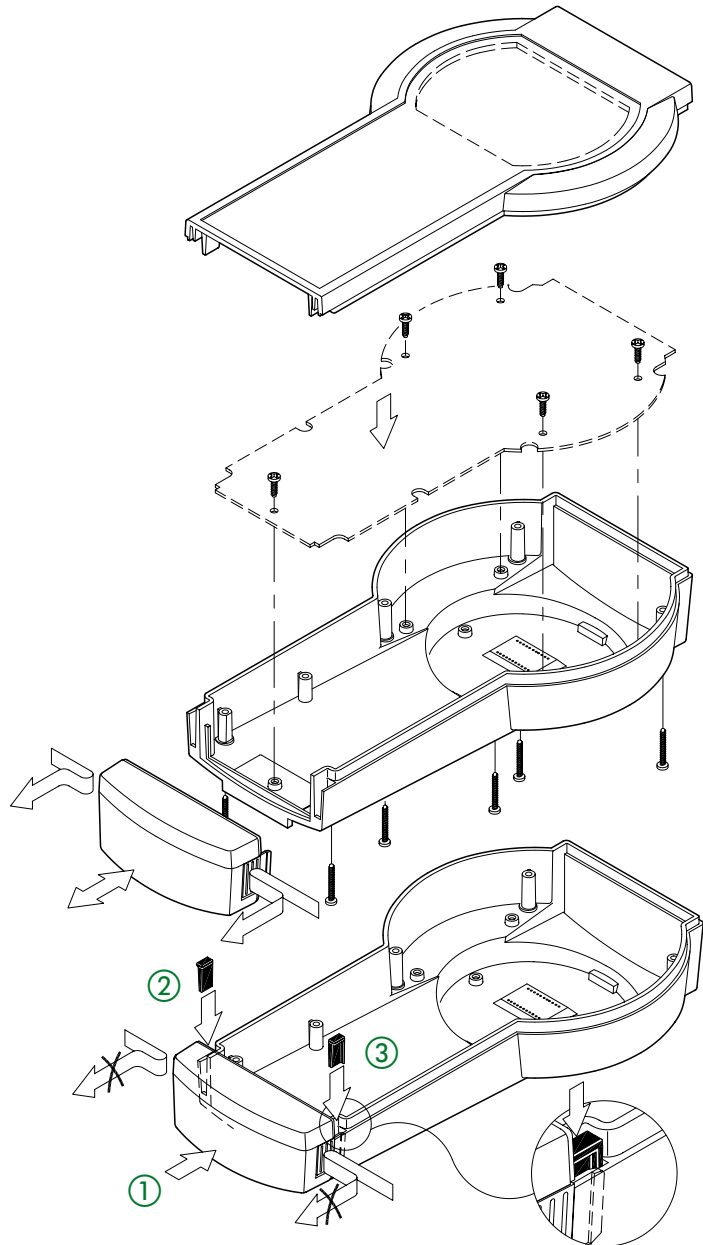

►  
Abdeckkappe  
nur gerastet

End cover only snapped-in  
Couverture  
seulement encliqueté

oder / or / ou

►  
Abdeckkappe  
mit den Stiften fixiert

End cover snapped-in  
and fixed with the pins  
Couverture encliqueté  
et avec fixation  
avec goupilles

Displayscheibe  
Display window  
Plaque

M	L
A 90 78 001	A 90 79 001

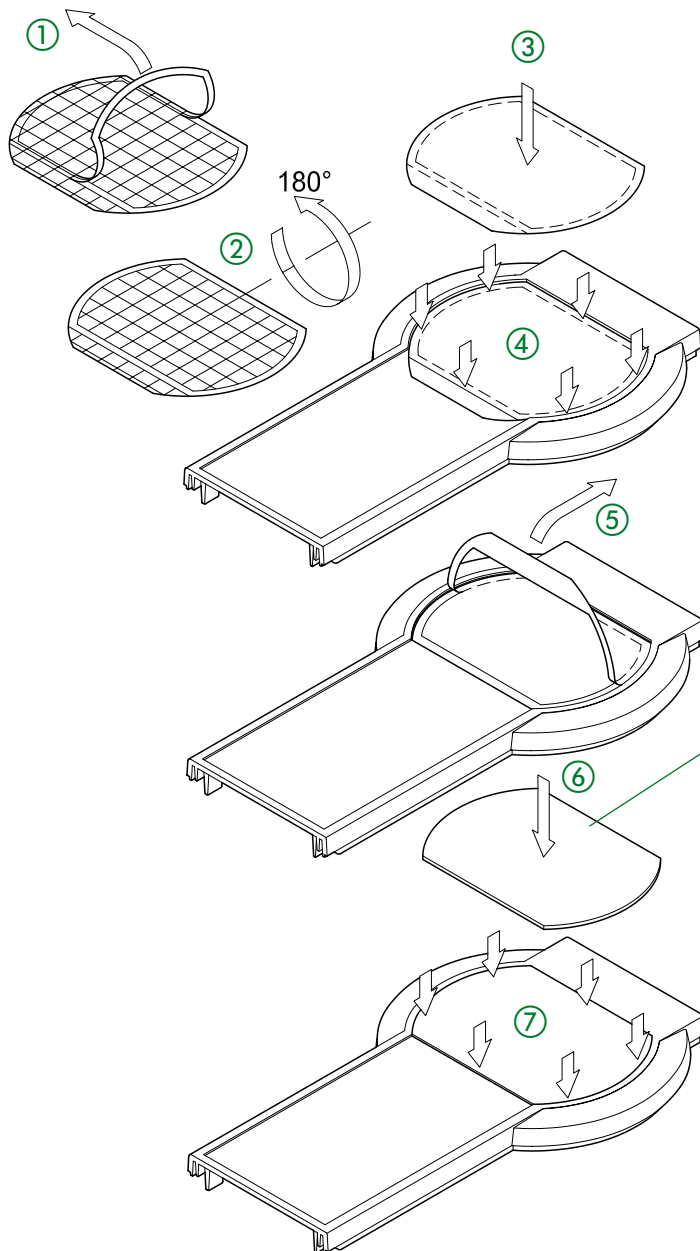

Bitte Montage-  
reihenfolge beachten!

Please respect the  
succession of mounting!

Veuillez respecter  
la suite de montage!

Die strukturierte Seite  
sollte wegen der  
„Entspiegelung“ oben sein!

The mat-finished side  
should be on top side!

Le côté antireflet doit  
être en haut!

Sockel, Tischversion  
 Station, desktop version  
 Socle, version de table

A 91 78 137

A 91 78 139

Bitte Montage-  
 reihenfolge beachten!

Please respect the  
 succession of mounting!

Veuillez respecter  
 la suite de montage!

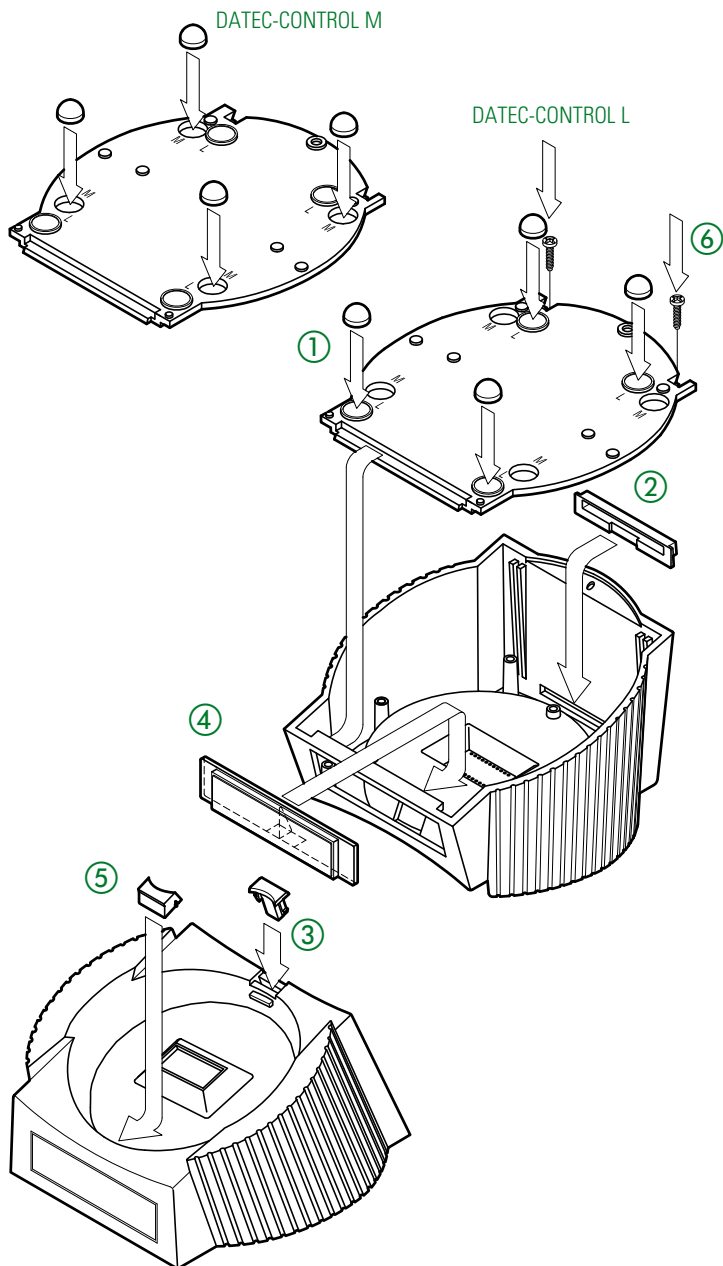

Socket, Wandversion  
Station, wall mounting  
Socle, version murale

M	L
A 91 78 167	A 91 78 169

Schlüssellöcher für  
Wandbefestigung durchbrechen.

Key holes for wall mounting sus-  
pension to be opened.

Percer des près-découpes  
pour montage murale.

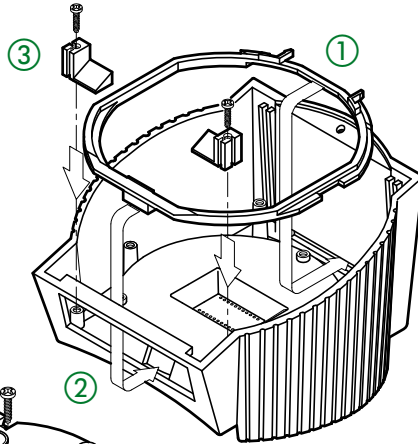

Bitte Montage-  
reihenfolge beachten!

Please respect the  
succession of mounting!

Veuillez respecter  
la suite de montage!

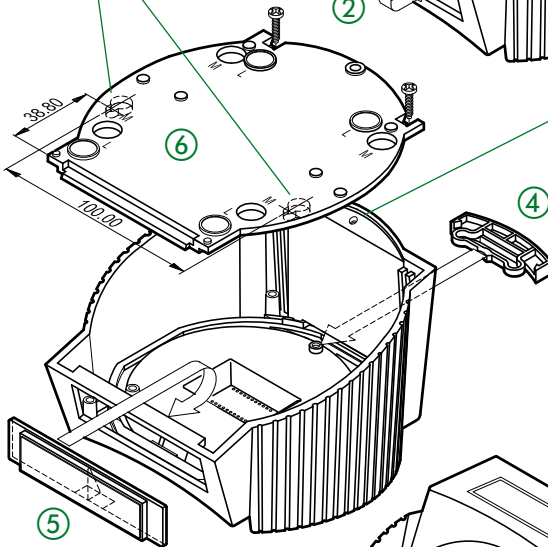

Vorgeformter Durchbruch für  
Wandbefestigung durchbrechen

Open prefabricated hole  
for wall mounting.

Ouvrir le trou pre-fabriqu  
pour le montage murale.

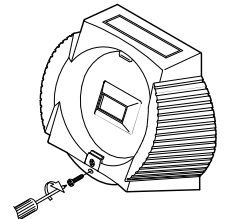
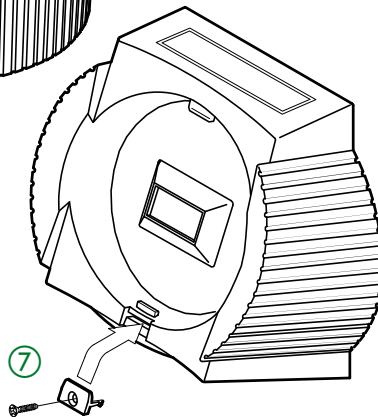

Halter für Batteriefach  
 Battery compartment holder  
 Support du  
 compartiment piles

A 91 78 118

Abdeckung  
 für Elektronikraum  
 End plate  
 for electronic area  
 Recouvrement  
 pour la partie électronique

A 91 78 178

A 91 78 188

A 91 78 198

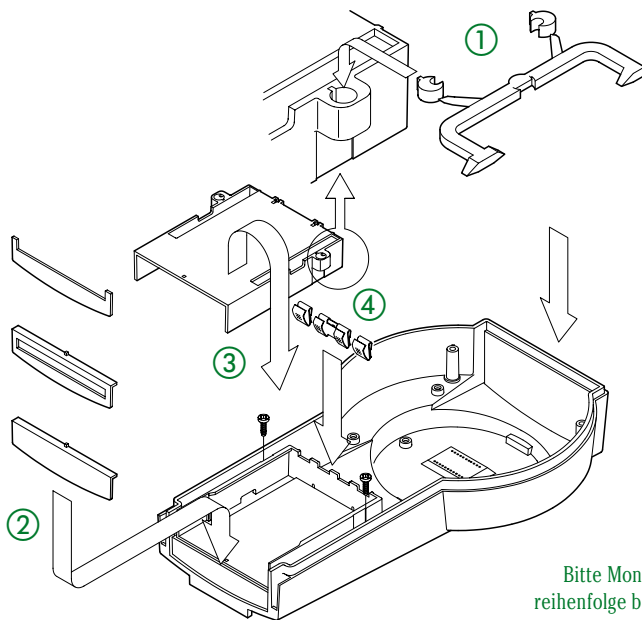

Bitte Montage-  
 reihenfolge beachten!

Please respect the  
 succession of mounting!

Veillez respecter  
 la suite de montage!

oder / or / ou

Bodenplatte vom Sockel mit  
 Halter für das Batteriefach.

Bottom plate of the station  
 with holder for battery  
 compartment.

Plaque inférieure du socle  
 avec support pour  
 compartiment piles.

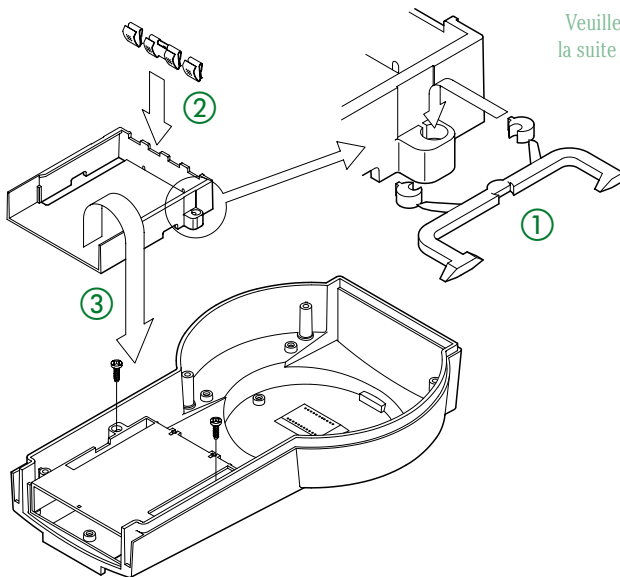
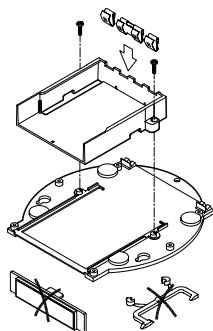

Batteriefach  
Battery compartment  
Compartment piles

A 91 78 128

A 91 78 158

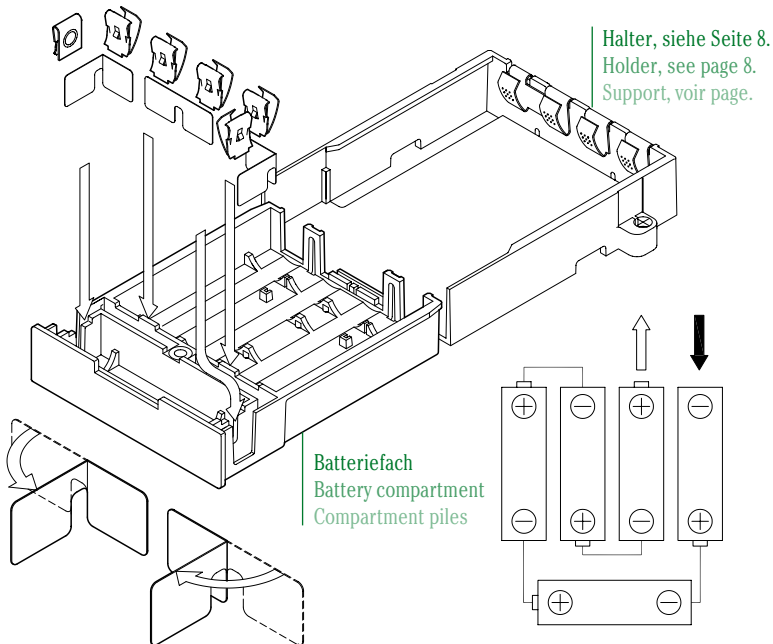
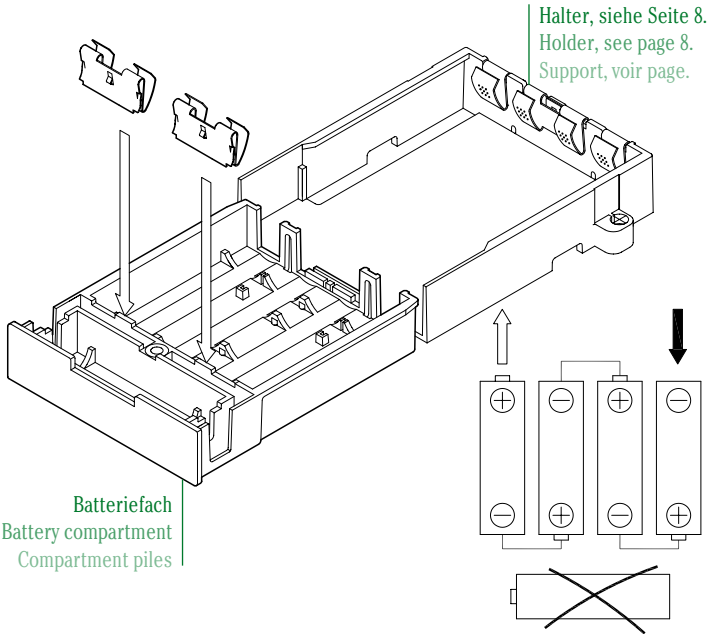

PCMCIA-Karte  
 PCMCIA-Card  
 PCMCIA-Carte

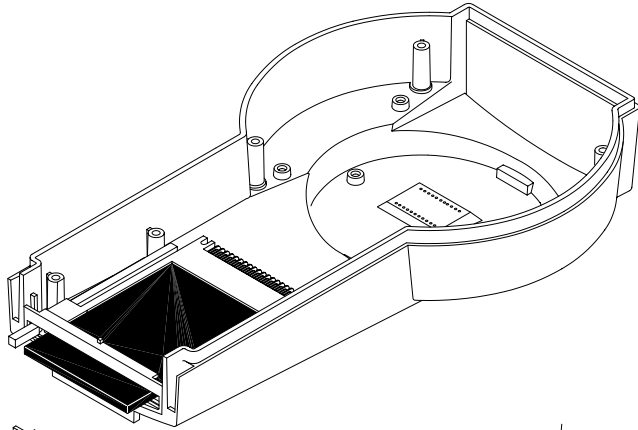

Abdeckung  
 für Elektronikraum  
 End plate  
 for electronic area  
 Recouvrement  
 pour la partie electronique

- A 91 78 188
- A 91 78 198

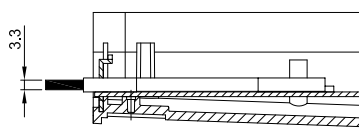
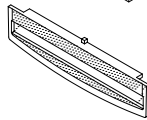

PCMCIA  
 TYP I

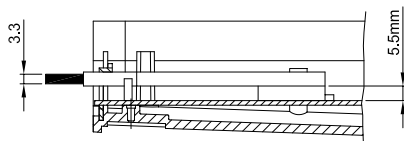
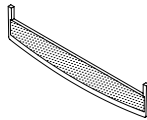

PCMCIA  
 TYP I

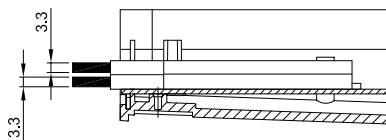

PCMCIA  
 TYP I

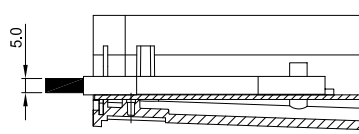

PCMCIA  
 TYP II

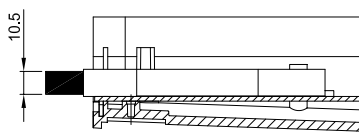

PCMCIA  
 TYP III

Kontakte  
Contacts

für das Gehäuse  
for the enclosure  
pour le boîtier

A 91 78 008

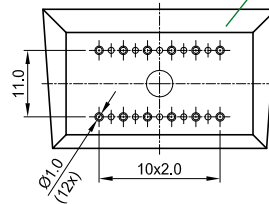
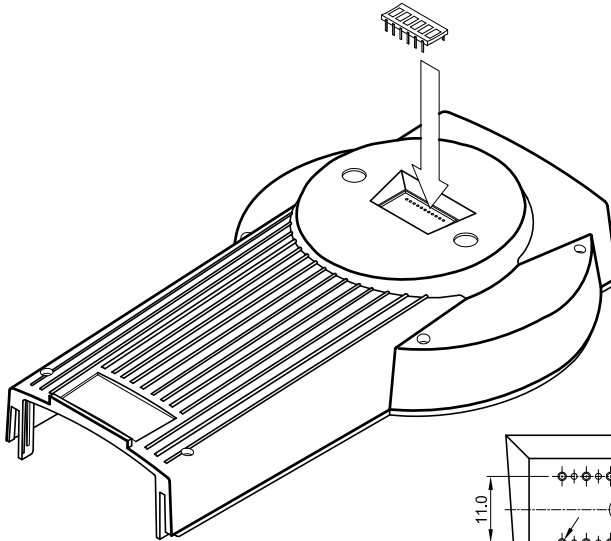

nur die ⊗ markierten  
Positionen müssen für  
den Einsatz von A 91 78 008  
durchbohrt werden (12x)

only the holes marked  
with ⊗ have to be drilled for  
the use of A 91 78 008 (12x)

il faut seulement percer les  
trous marqués avec ⊗ pour  
l'usage du A 91 78 008 (12x)

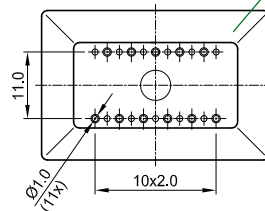
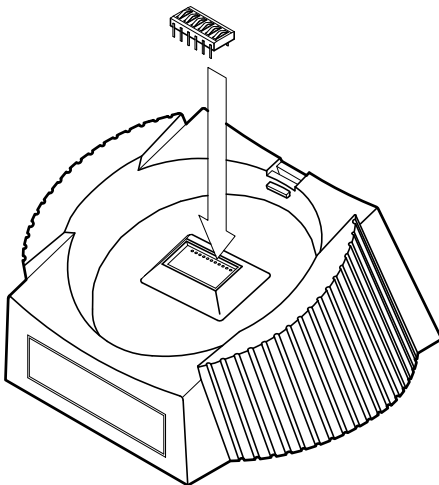

für den Sockel  
for the station  
pour le socle

A 91 78 007

nur die ⊗ markierten  
Positionen müssen für  
den Einsatz von A 91 78 007  
durchbohrt werden (11x)

only the holes marked  
with ⊗ have to be drilled for  
the use of A 91 78 007 (11x)

il faut seulement percer les  
trous marqués avec ⊗ pour  
l'usage du A 91 78 007 (11x)

## Dichtungs-Set

Bitte Montager Reihenfolge ① bis ⑤ beachten – Schutzartverlust bei nicht ordnungsgemäßer Montage!

## Sealing kit

Please respect the mounting order ① to ⑤ – loss of protection class, if not mounted correctly!

## Jeu de joints

Veuillez respecter la suite de montage ① jusqu'à ⑤ – perte de protection quand le joint n'est pas monté correctement!

① jusqu'à ⑤ –  
perte de protection  
quand le joint n'est pas  
monté correctement!

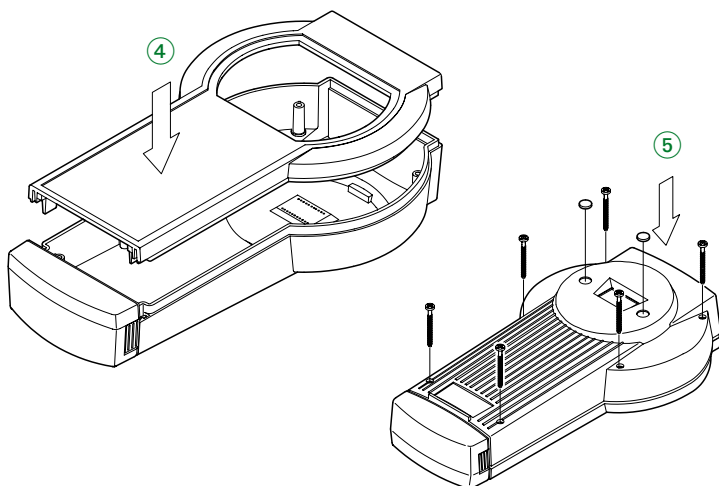
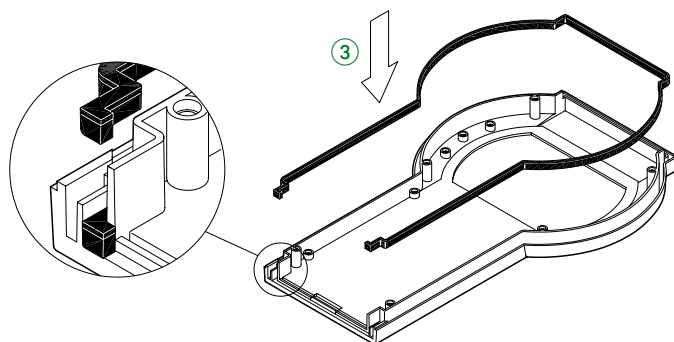
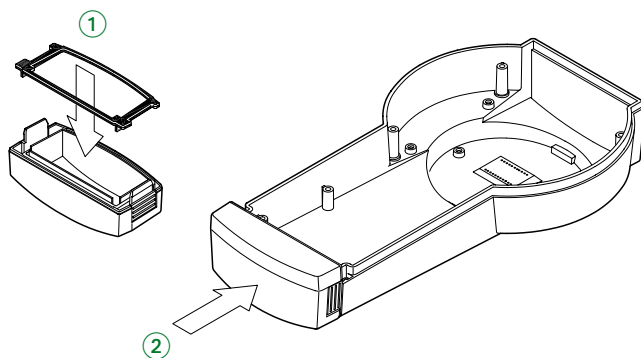

M	A 91 78 006
L	A 91 79 006

Maximale Abmessungen  
der Leiterplatten.

Maximale Dimensions  
for PCBs.

Maximales  
encombrement pour  
circuits imprimé.

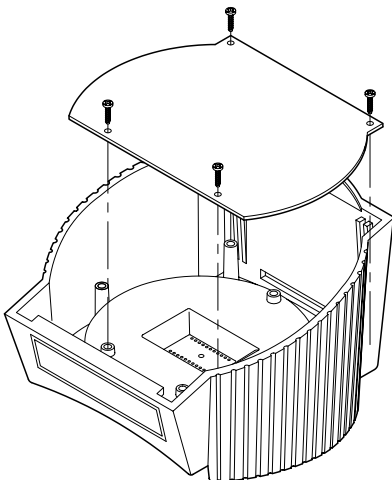
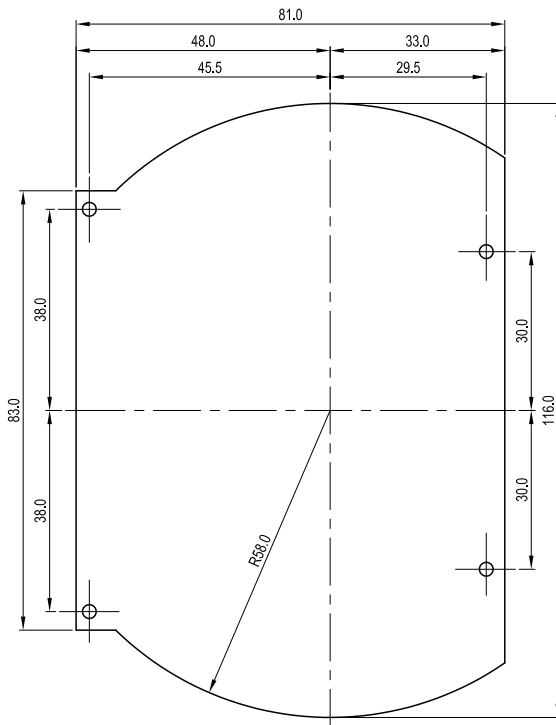



Maximale Abmessungen  
der Leiterplatten.

Maximale Dimensions  
for PCBs.

Maximales  
encombrement pour  
circuits imprimé.

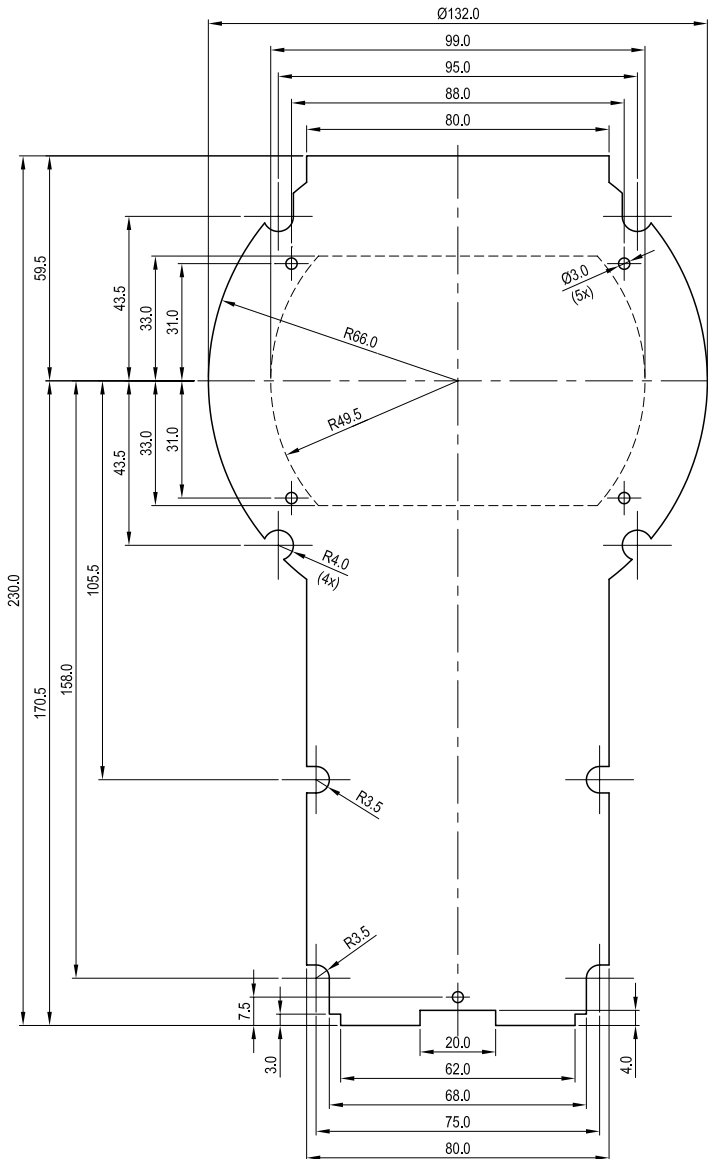

## ASSEMBLY INSTRUCTION – INSTRUCTION DE MONTAGE MONTAGEANLEITUNG

Subject to technical modification,  
typographical and other errors  
without prior notice.  
A9179142 – 11.2011

Odenwälder Kunststoffwerke  
Gehäusesysteme GmbH  
Friedrich-List-Str. 3  
Im Industriegebiet III  
74722 Buchen/Germany  
[www.okw.com](http://www.okw.com)

